

# **Prizelawn® LF II**

## **COMMERCIAL BROADCAST SPREADER**

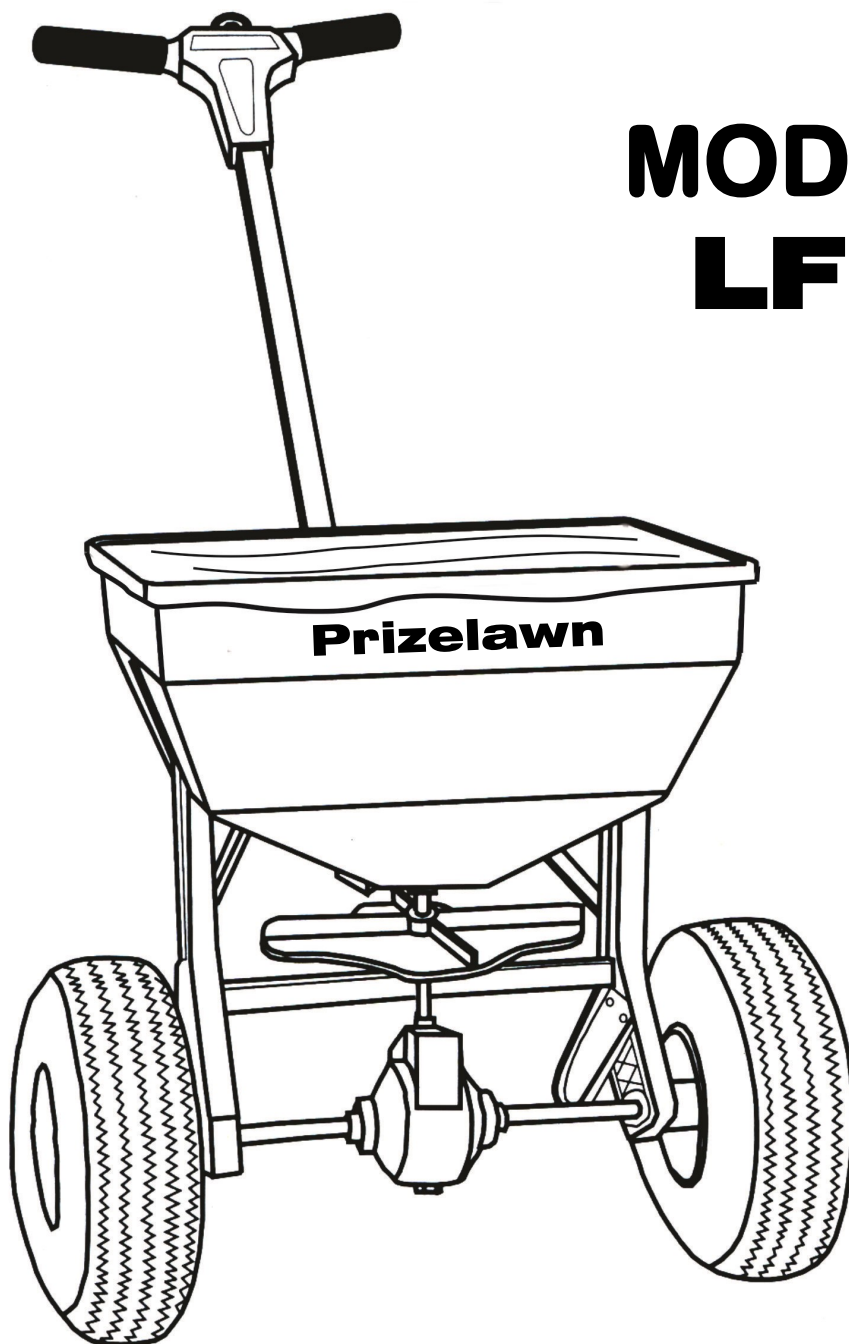

**MODEL  
LF II**

6-21-2016

# **OWNER'S MANUAL**

# ASSEMBLY INSTRUCTIONS

**1.** Remove the spreader and components from the carton. Turn spreader upside down. Insert (2) 1/4-20 x 1 1/2" hex bolts through the flattened end of handle brace, frame and leg as shown. Install hex nuts but do not tighten. Repeat on opposite side.

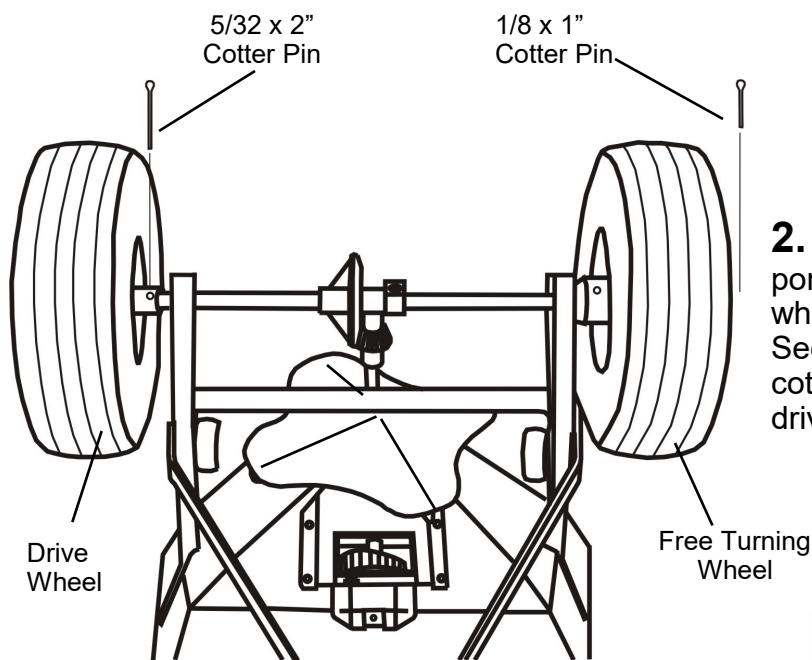
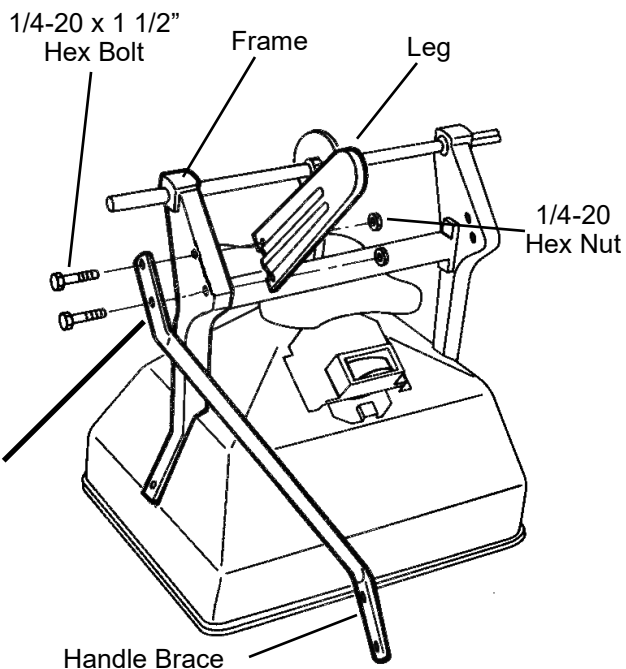

**VIEWED FROM REAR OF SPREADER**

**2.** Slide wheels onto axle with the longer portion of the wheel facing the frame. The wheels are identical to ease assembly. Secure free turning wheel with (1) 1/8 x 1" cotter pin and (1) 5/32 x 2" cotter pin on the drive wheel.

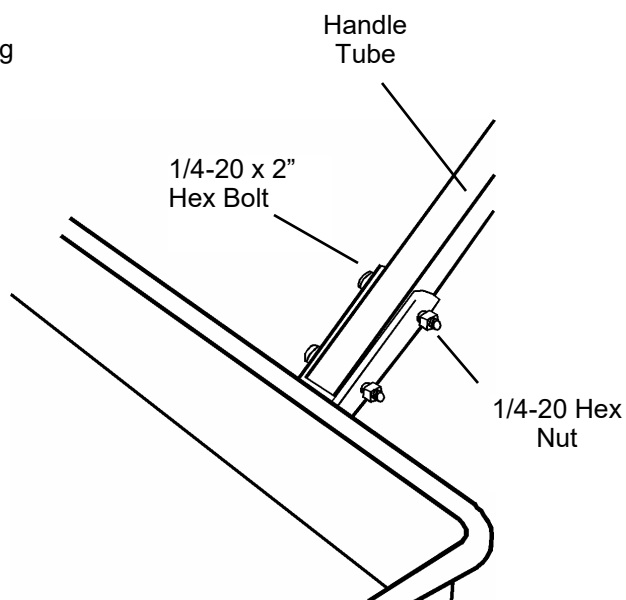

**3.** Turn spreader upright and install handle tube between braces. Push down. Dot on bottom. Secure with (2) 1/4-20 x 2" hex bolts and nuts. Tighten handle brace nuts installed in step 1.

# ASSEMBLY, CONTINUED

**4.** Feed control knob/wire through the T-handle until spring touches the round hole. CAUTION: Do Not Compress Spring At This Time. Feed wire through the square handle tube. Be sure wire passes above the bolts in the handle brace. Secure T-handle to the tube with (1) 1/4-20 x 2" hex bolt, (2) washers, and (1) hex nut in the bottom hole, and (1) 1/4-20 x 2 1/4" hex bolt, (2) washers, and (1) hex nut in the top hole as shown. Remove caution label and push the thumb release toward the center and push down knob and shutoff spring until knob latches.

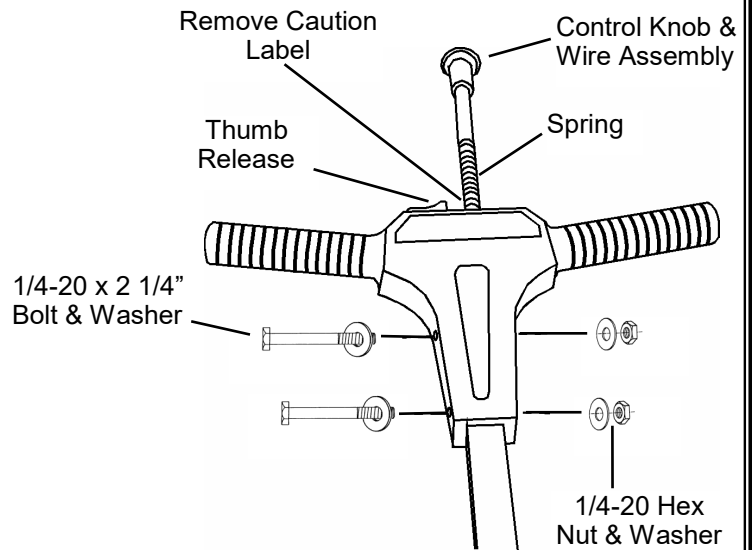

**CAUTION: ONCE KNOB IS LATCHED, DO NOT MOVE THUMB RELEASE UNTIL YOU HAVE COMPLETED STEP #5.**

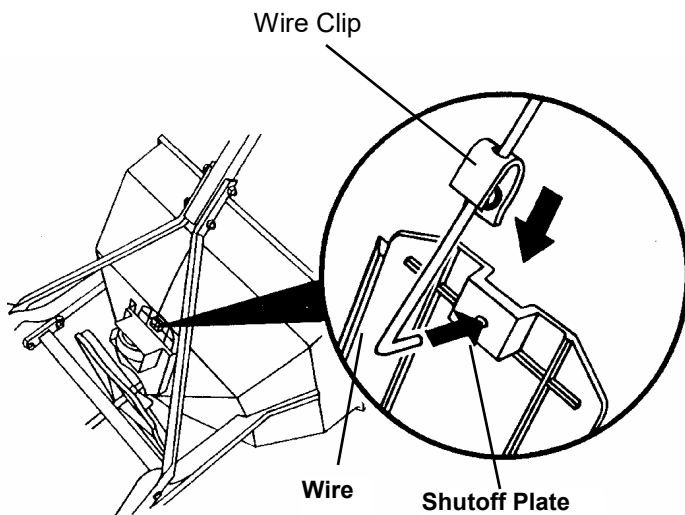

**5.** Slide wire retaining clip onto wire as shown. Insert wire through hole shutoff plate. Slide wire retaining clip over shutoff plate and wire until the clip locks into place.

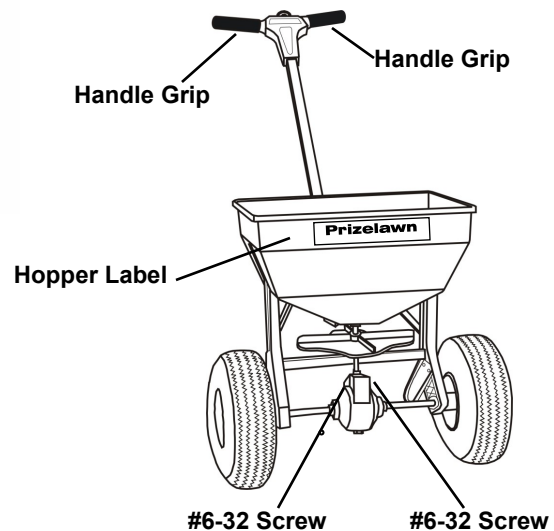

**6.** Install gear cover assembly over gears and secure with (2) #6-32 screws. Install the hopper label onto the front of the spreader as shown. Slide handle grips onto handle. Soapy water will ease installation. (Do not use petroleum based products.) The **LF II** spreader should now be completely assembled and ready for use.

# SPREADER OPERATION

**1.** Check the product package for the rate setting, and recommended swath width. Turn the spreader off by pushing the control knob in. Rotate the rate cam to the proper setting.

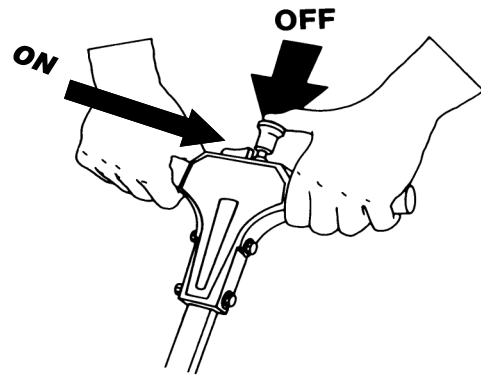

**2.** Always fill the spreader on the driveway or sidewalk-not on the lawn. Make sure spreader is in the "OFF" position. Empty after each use.

**3.** Start spreader moving, then open spreader by pushing the thumb release to the "ON" position. Always push spreader, never pull. Push knob down to close spreader.

**4.** Hold handle so top of spreader is level. Tipping the spreader too far can cause uneven spreading.

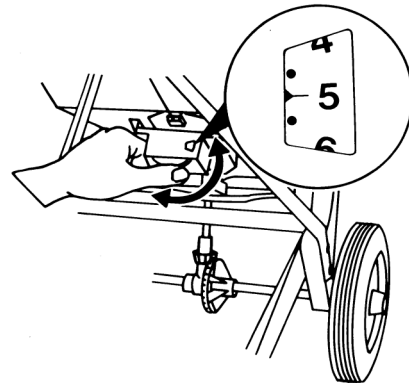

**5.** The settings and swath widths on the product label are recommended starting points. Always check the delivery rate and pattern on a small area before treating a large area. Actual delivery rate can vary due to weather conditions, operating variables, and condition of the product being applied. See "HOW TO DETERMINE SPREADER SETTING AND SWATH WIDTH" for details.

**6.** Push spreader 3 1/2 m.p.h. (26 feet in 5 seconds) for full 8' to 10' spread pattern when applying fertilizer products. Apply header strips at each end of area to be treated then space trips across the area as shown.

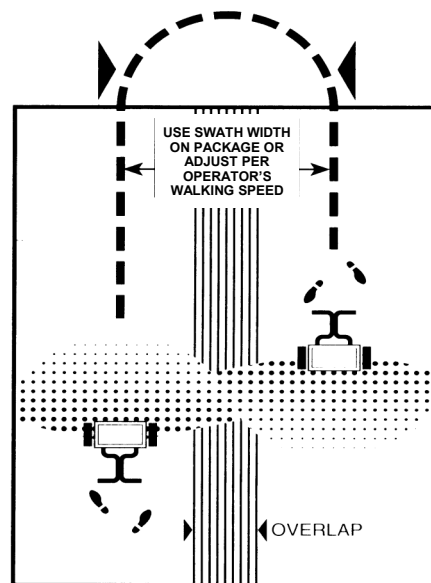

**7.** Push spreader at 2 1/2 mph (18 feet in 5 seconds) to reduce width of spread when applying ice melt products to sidewalks.

**8.** Empty spreader after each use. Return leftover material to its original container.

# HOW TO DETERMINE SPREADER SETTINGS AND SPREAD WIDTH

Two major factors should be considered when determining correct spreader settings of any product:

1. The product application rate, or the amount of material applied per 1,000 square feet.
2. The effective pattern width, or the actual width in which material is applied. Label settings are a guide and can be affected by numerous factors.

## EFFECTIVE PATTERN WIDTH

A simple visual pattern test can be made by operating the spreader over a non-turf area and evaluating the pattern. A more accurate method is to place a row of common, disposable, aluminum cake pans approximately 1 foot on centers. Set the rate cam at a middle setting and make 3 or 4 passes in the same direction as shown. Pour the material collected from each pan into individual bottles of the same size. Set them side by side in order, and visually inspect their volume. The effective pattern width is the distance out from the spreader to a point where the amount of material is 1/2 the average amount in the center pans. This distance is multiplied by 2 to achieve the total effective pattern width.

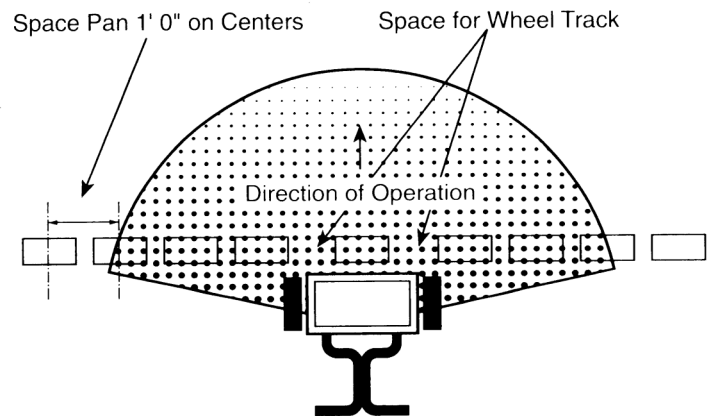

## APPLICATION RATE

Knowing the effective pattern width (for example, 10 feet), measure a distance equal to 100 square feet (10' x 10' swath width). Determine the product coverage is pounds/ 100 sq. ft. by the recommended square foot coverage (add two zeroes to the weight of the bag).

EXAMPLE: Product weight: 25 lbs.  
sq. ft. coverage: 5,000 sq. ft.  
2500 lbs. - 5,000 sq. ft.  
= .5 lbs. / 100 sq. ft.





Weigh out between 15 to 20 lbs. of material and spread over the 100 sq. ft. area. Weigh remaining material left in hopper and adjust rate setting as required. Repeat test until application rate is correct.

# RATE SETTING CONVERSION

The following provides approximate **Prizelawn® LF II** settings for those units listed.

<b>Prizelawn® LF II Setting</b>	2	3	4	5	6	7	8	9	10	11	12	13	14	15	16	17	18
<b>Scotts Speedy Green Setting</b>	2	3	4	5	6	7	8	9	10	11	12	13	14	15	16	17	18
<b>Prizelawn BF I / BF1SS Setting</b>	E	I	K	M	O	R	W	Z	—	—	—	—	—	—	—	—	—
<b>Lesco #029600 Setting</b>	D	—	H	—	K	M	Q	S	—	—	—	—	—	—	—	—	—
<b>Scotts R8A/ SR-1 Setting</b>	G	K	M	O	Q	T	—	Z	—	—	—	—	—	—	—	—	—
<b>Earthway 2200/2400 Setting</b>	10	—	15	17	19	22	26	30	—	—	—	—	—	—	—	—	—
<b>Spyker 76/78-2 Setting</b>	4	—	5	6	7	8	9	10	—	—	—	—	—	—	—	—	—

The following provides approximate **Prizelawn® LF II** settings when only the product weight, square foot coverage, and visual inspection of the material is available.

FERTILIZER PARTICLE SIZE	BAG RATE Pounds of fertilizer used per 1,000 sq. ft. of coverage	APPROX. SETTING	SPREAD WIDTH (IN FEET)
<b>Large, heavy particles</b> 	5	3 1/2	8
	10	4	8
	15	4 1/2	8
<b>Medium- mixed particles</b> 	5	2 1/2	8
	10	3 1/2	8
	15	4	8
<b>Small particles (nitrogen)</b> 	1	2	8
	2	2 1/2	8
	3	3	8
<b>Mixed size particles -some fines</b> 	5	3	6
	10	3 1/2	6
	15	4	6
<b>Light weight particles</b> 	5	2	4
	10	2 1/2	To
	15	3	6

Conversions should be used as guidelines for establishing proper rate settings. To obtain the most accurate application rate, follow the procedures described in the Effective Pattern Width and Application Rate sections. The settings shown here are only approximations and will vary due to physical characteristics of the product, walking speed, turf condition, humidity, etc. Warranty and guarantees of actual coverage or uniformity are neither expressed nor implied.

# MAINTENANCE

1. Never store unused material in spreader. Return unused product to its original container.
2. Wash spreader thoroughly after each use and dry completely in sun or heated area.
3. Oil the axle bearings, impeller shaft bearing in hopper, control knob in the T-handle.
4. Remove gear cover and wash gears thoroughly. Oil all bearing areas and face of gear teeth. Re-install gear cover.
5. Gear mesh should be checked on a regular basis during high use periods. Clearance between the axle gear and pinion gear should be minimal but not tight. If adjustment is necessary, loosen axle collar set screw and hold gears together. Slide axle collar against the gear support and tighten axle collar set screw. Spin drive wheel. Gears should run freely and smoothly.
6. Impeller surface should be cleaned periodically to remove build-up of product. Build-up can cause the spread pattern to change.
7. Tire pressure should be 20-25 PSI.

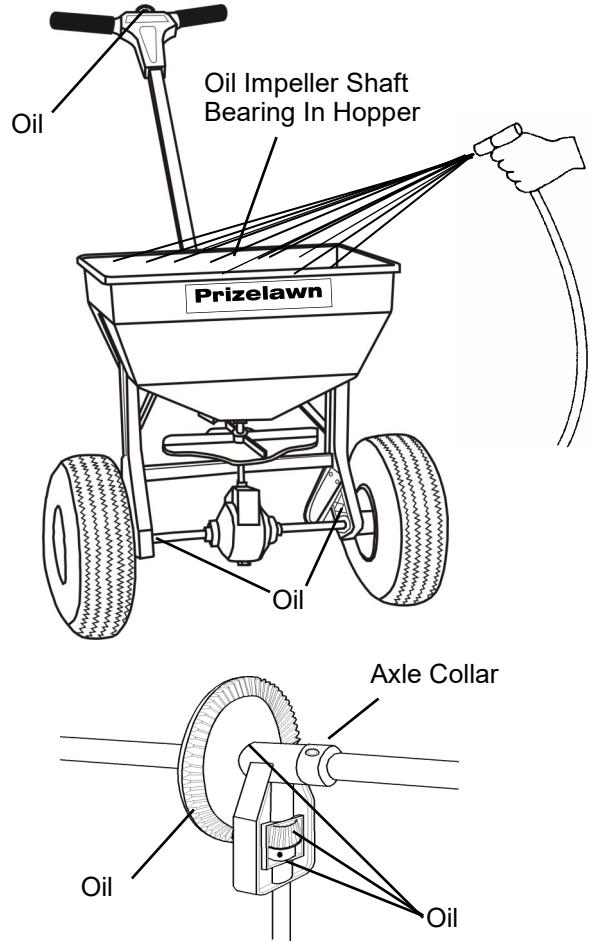

# WARRANTY

## Prizelawn warrants to Purchaser the following:

1. Product will be free of defects in materials and workmanship for a period of one year from date of purchase.
2. PRIZELAWN will decide in its reasonable discretion if the part(s)/unit is defective.
3. The spreader or part(s) will be shipped to PRIZELAWN at the customer expense with a written description of defect to the attention of PRIZELAWN WARRANTY DEPARTMENT.
4. If the spreader is used for commercial rental the Limited Warranty shall be limited to a period of 90 days.
5. All Unit and part replacement will be performed at the reasonable discretion of PRIZELAWN.
6. Labor charges are not covered and the unit need not be returned to the dealer for warranty service.
7. Proof of purchase must be supplied to PRIZELAWN.

PRIZELAWN's sole obligation under this warranty is limited to repairing or replacing the defective part. Upon replacement of any Product or Product part, the replaced item shall become the property of PRIZELAWN. If PRIZELAWN determines that the Product covered by this warranty requires service, PRIZELAWN shall prepay return shipping charges from PRIZELAWN. In all other instances, such charges shall be paid by Purchaser. Except for loss or damage caused by PRIZELAWN's negligence, Purchaser relieves PRIZELAWN of responsibility for all risks of loss or damage to the Product and its parts during the period the products are in transit to and from PRIZELAWN.

This warranty does not extend to any Product or parts thereof that have been allowed to corrode, subjected to misuse, neglect, accident, or modification by anyone other than PRIZELAWN or that have been affixed to any nonstandard accessory attachment or that have been used, stored, installed, maintained or operated in violation of PRIZELAWN's instructions or standard industry practice. No agent, employee or representative of PRIZELAWN has any authority to bind PRIZELAWN to any affirmation, representation or warranty concerning the Product and any affirmation, representation or warranty made by any agent, employee or representative shall not be enforceable by Purchaser.

**THIS WARRANTY EXTENDS ONLY TO THE ORIGINAL PURCHASER AND IS EXPRESSLY IN LIEU OF ANY OTHER EXPRESS OR IMPLIED WARRANTIES, INCLUDING WITHOUT LIMITATION ANY IMPLIED WARRANTY OR MERCHANTABILITY OR FITNESS OR INTENDED USE FOR A PARTICULAR PURPOSE AND OF ANY OTHER OBLIGATION ON THE PART OF PRIZELAWN. PRIZELAWN SHALL NOT BE LIABLE FOR ANY INCIDENTAL, SPECIAL OR CONSEQUENTIAL LOSS, DAMAGE OR EXPENSE DIRECTLY OR INDIRECTLY ARISING FROM THE USE OF ANY OF THE PRODUCT INCLUDING, BUT NOT LIMITED TO, DAMAGE OR LOSS OF OTHER PROPERTY OR EQUIPMENT, LOSS OF PROFITS OR REVENUE, COST OF CAPITAL, COST OF PURCHASED OR REPLACEMENT GOODS, OR CLAIMS OF CUSTOMERS OF PURCHASER.**

# PARTS LIST FOR Prizelawn® LF II

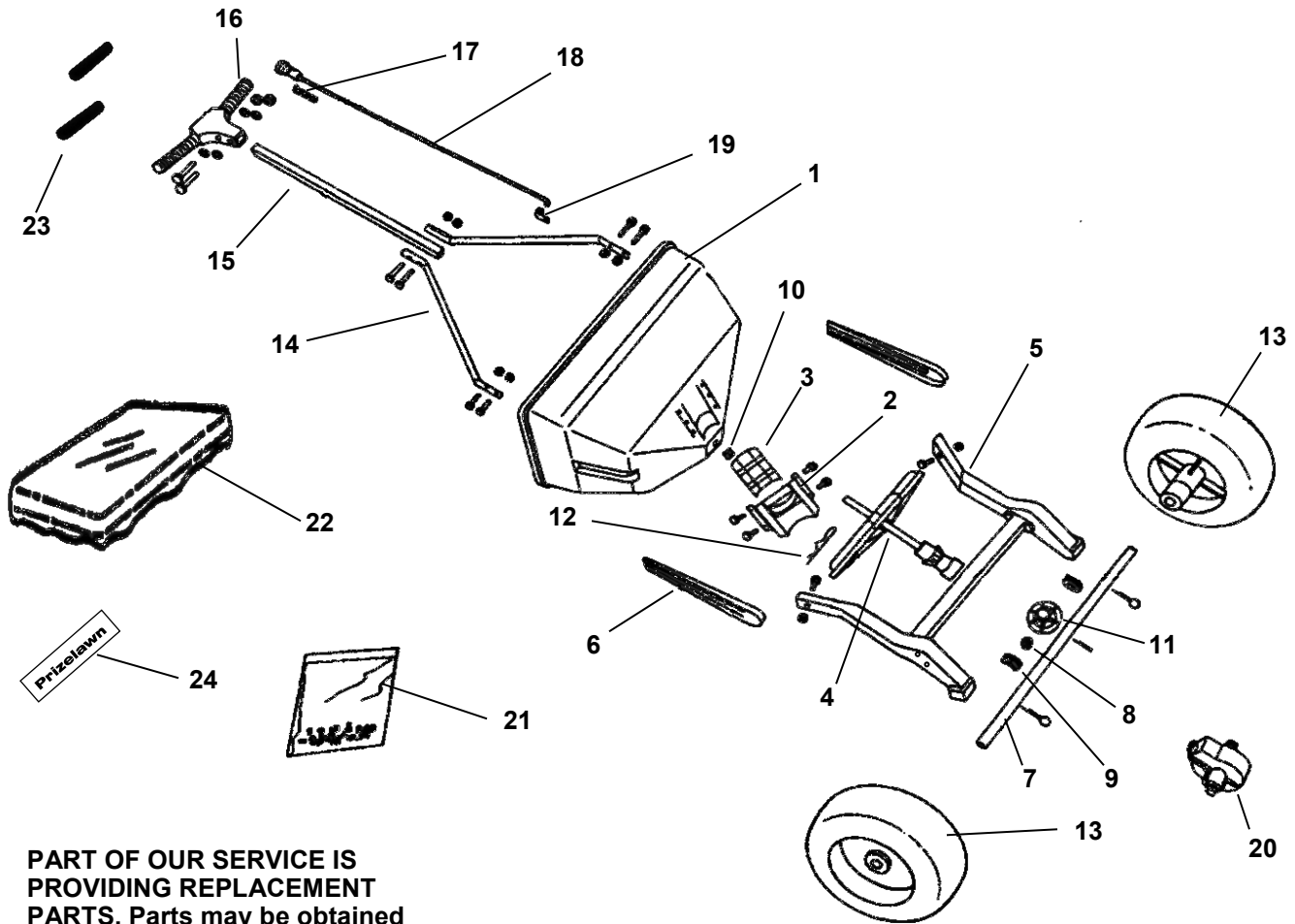

PART OF OUR SERVICE IS PROVIDING REPLACEMENT PARTS. Parts may be obtained through your local distributor. Be sure to give:

1. SPREADER MODEL NUMBER
2. SPREADER NAME
3. PART NUMBER
4. NAME OF PART AS SHOWN

IF YOUR LOCAL DISTRIBUTOR CANNOT SUPPLY PARTS, CONTACT:

**Prizelawn®**

c/o Earthway Products, Inc.  
1009 Maple Street / PO Box 547  
Bristol, IN 46507

Ph: 800-294-0671 / Fax: 574-848-4249  
[www.prizelawnspreaders.com](http://www.prizelawnspreaders.com)

KEY	DESCRIPTION	PART NO.	KEY	DESCRIPTION	PART NO.
1	Hopper Ass'y-includes #2&3	14508-1	13	Drive & Free Turning Wheel	14939-1
2	Rate Cam & Chute Assembly	14455-1	14	Handle Braces (2)	13613-1
3	Shutoff Plate	14454-1	15	Handle Tube	14513-1
4	Impeller Assembly	15849	16	T-Handle Assembly	13634-2
5	Frame Assembly	15838	17	Control Knob Spring	14462
6	Legs (2)	13619-1	18	Control Knob & Wire Ass'y.	13640-1
7	Axle	15842	19	Wire Retaining Clip	13643-1
8	Axle Collar	14634	20	Gear Cover Assembly	13623-1
9	Axle Bushings (2)	14951	21	Fastener Package	15880
10	Impeller Shaft Bearing	15833	22	Hopper Cover	15209
11	Axle Gear	13625-1	23	Handle Grip (2)	15264
12	Agitator	15866	24	Hopper Label	16465